

BROWN SAFE

BROWN SAFE

Congratulations on the purchase of your finely crafted Brown Safe. We sincerely appreciate the trust your purchase represents and take great pride in securely protecting your treasured valuables.

Setting Up Your Safe

Selecting a Location	2
Powering Interior Features	3
Alarm Wiring Diagrams	4

Bolt Down Instructions

Concrete Floor	7
Wood Floor	9

Dial Lock

Operating Instructions	13
Setting a New Combination	15

Electronic Lock Identification 19

Electronic Lock

Operating Tips	22
Operating Instructions	23
Setting a New Combination	24
Changing Batteries	25
Sending Silent Distress Signal	26

Gen. II Electronic Lock

Operating Tips	27
Operating Instructions	29
Setting a New Combination	31
Adding a New User	32
Turning Backlight Off/On	33
Turning Sound Off/On	34
Changing Batteries	35
Sending Silent Distress Signal	36

Biometric Lock

Operating Tips	37
Operating Instructions	39
Setting a Master Code	41
Setting a User Code	42
Enrolling a Fingerprint For First Time	43
Adding a New User	45
Deleting a User	49

Biometric Lock (Cont.)

Changing Entry Method	50
Emergency Opening with Code Only	53
Changing Batteries – Standard Display	56
Changing Batteries – Chronos Intro	59
Changing Batteries – Chronos Oval Display	61
Changing Batteries – Chronos Integrated Display	64
Loss of AC power – Chronos Oval Display	67
Loss of AC power – Chronos Integrated Display	69

Vault Door - Electronic Lock with Dial Lock Back Up

Operating Tips	71
Operating Instructions	73
Electronic Lock - Setting a New Combination	74
Electronic Lock - Changing Batteries	75
Dial Lock - Operating Instructions	76
Inner Escape Device Operation	77
Panic Slide Latch Operation	79

3 Movement Mechanical Timelock

Operating Instructions	81
Timelock Release	82

Silent Signal Alert

Sending Signal Via Electronic Lock	83
Sending Signal Via Panic Button	84

Watch Winders

Programmable Watch Winders	85
Rotorwind Watch Winders	91
Watch Winder Carousel	97

Safe Interior

Adjusting Standard Interior Shelves	99
Changing Drawer Inserts	103
Removing Drawer Detents	105
Removing Standard Drawers	107
Removing Undermount Drawers	109

Setting Up Your Safe

Thank you for purchasing!

As the premier manufacturer of high quality safes and vaults built to a higher standard, Brown Safe commends your decision to invest in protecting your valuables.

Please take a moment to review this information and begin enjoying your new safe.

Setting Up Your Safe - Selecting A Location

Here are a few tips to keep in mind when selecting a location for your new safe:

- Consider installing your safe in an accessible location where you can conveniently access your valuables.
- Allow enough room for the door to fully open and allow for unobstructed access to interior shelving and drawers.
- Avoid placing safe near foundation walls in a way that would create a gap of 8"-18" whenever possible. This will eliminate the ability to leverage the safe away from the wall using a car jack to rip the safe's base anchor bolts out of the flooring.
- Anchor the safe to the floor using the supplied anchor bolts. See *Bolt Down Instructions* for step by step process.

Setting Up Your Safe - Powering Interior Features

If your new safe has any luxury features that require electricity, such as interior lights or watch winders, you'll need to plug in the cords exiting the back of safe to supply power to those features.

1. Locate the power cord(s) at back of safe on hinge side.
2. Unwrap and extend the cords, making sure they are free of any tangles or obstructions.

Note: Orbita watch winders require attachment of power adapter (stored within safe during shipping) to cord exiting back of safe.

3. Insert the plug(s) into an available A/C outlet.

Note: Clients outside the U.S. will have the appropriate power adapter included.

Setting Up Your Safe - Alarm Wiring Diagram

Safes equipped with a Panic Button or the Silent Signal alarm feature require integration with the home automation or home security systems. The gray five conductor cable exiting the back of safe on hinge side contains the necessary wiring to connect to the correct system.

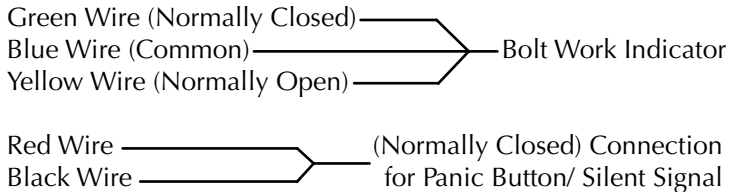

Note: Relay jumper switch can be switched to Normally Open if needed (see diagram on following page).

Setting Up Your Safe - Alarm Wiring Diagram

The relay jumper switch is located under the boltwork cover and can be positioned to Normally Open if necessary.

Note: Normally Closed is the default position.

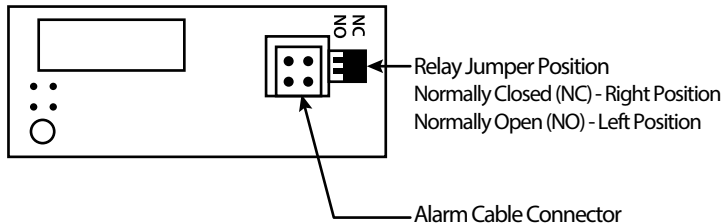

Setting Up Your Safe - Chronos Alarm Wiring Diagram

Chronos Safes equipped with a Panic Button or the Silent Signal alarm feature require integration with the home automation or home security systems. The gray four conductor cable exiting the back of safe on hinge side contains the necessary wiring to connect to the correct system.

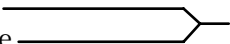
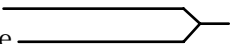
Blue Wire  (Normally Open) Connection
Yellow Wire  for Bolt Work Indicator

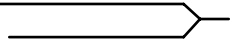
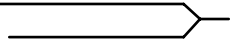
Red Wire  (Normally Open) Connection
Black Wire  for Panic Button/ Silent Signal

Bolt Down Instructions - Concrete Floor

1. Position safe in desired location and check for proper door swing clearance, making sure it does not interfere with interior drawers, concealment cabinetry, closet doors, etc.
2. When you are satisfied with the safe's position, locate the bolt holes in the bottom of the safe and drill a 5/8" hole through the right rear hole of the unit approximately 1/2" deeper than the length of the anchor. Be careful not to drill completely through the slab.
**If necessary remove safe interior floor plate or bottom drawers to expose bolt holes.*
3. Clean hole of all excess concrete particles and dust.
4. With a bolt partly screwed into the anchor. Place it into hole and gently tap it completely to the bottom of the hole, then remove the bolt to expose the wedge.

Bolt Down Instructions - Concrete Floor

5. Set (expand) anchor by driving wedge down with a 3/8" diameter pin punch through center of anchor with a hammer until it completely stops.
6. Place lock washer then flat washer on bolt and tighten down to 50 foot-pounds of torque (tight).
7. Repeat steps 2-6 on each of the remaining bolt holes.

Caution:

**On safes too small to drill from inside, the holes will have to be marked and drilled with the safe set aside and then repositioned after the anchors are set.*

**Great care should be taken to ensure the holes do not move around as they are being drilled. It is often helpful to drill 3/16" pilot holes to prevent the hole from drifting.*

Bolt Down Instructions - Wood Floor

1. Position safe in desired location and check for proper door swing clearance, making sure it does not interfere with interior drawers, concealment cabinetry, closet doors, etc.
2. When you are satisfied with the safe's position, locate the bolt holes in the bottom of the safe and drill a 3/8" hole through the right rear hole of the unit approx. 2 1/2" deep.
**If necessary remove safe interior floor plate or bottom drawers to expose bolt holes.*
3. Place lock washer, then flat washer on bolt and tap gently to start bolt into hole, then tighten down until snug. Take care to not over tighten.
4. Repeat steps 2-6 on each of the remaining bolt holes.

Bolt Down Instructions - Wood Floor

Caution:

- *On safes too small to drill from inside, the holes will have to be marked and drilled with the safe set aside and then repositioned after the anchors are set.*
- *Great care should be taken to ensure the holes do not move around as they are being drilled. It is often helpful to drill 3/16" pilot holes to prevent the hole from drifting.*

Dial Lock

The ideal choice for the traditionalist, the dial lock is a reliable and elegant means of providing secure access to your safe.

No electronics means no maintenance, guaranteeing that you'll have years of trouble-free dependability.

Mechanical Dial Lock Features:





- *Three combination wheels produces 1,000,000 possible combinations*
- *Integral relock trigger sets off relockers if lock is tampered with or punched.*
- *Brass wheels and lever offers long & dependable lock life.*
- *Dialing tolerance = +/- .5 degrees*

Dial Lock - Operating Tips

Please keep these tips in mind when utilizing your dial lock:

- 1. Always use the line at the 12 o'clock position when dialing your combination. This line is known as the opening index. (See Figure 1. on page 14)*
- 2. Prior to opening the safe make sure the handle is turned completely to the locked position.
Right side hinges = handle should be fully counter-clockwise.
Left side hinges = handle should be fully clockwise.*
- 3. Avoid putting pressure on the handle during combination entry as this may cause a locking bolt malfunction.*
- 4. Once the correct combination is entered turn handle to open position.
Right side hinges = Turn handle clockwise to open.
Left side hinges = Turn handle counter-clockwise to open.*
- 5. In the open position the safe's handle will rotate approximately 20 degrees.*

Dial Lock - Operating Instructions

1.  Turn the dial left (CCW) passing the first number in the combination three times. Then stop exactly on the number the fourth time.
2.  Turn the dial right (CW) passing the next number in the combination two times. Then stop exactly on the number the third time.
3.  Turn the dial left (CCW) passing the last number in the combination one time. Then stop exactly on the number the second time.
4.  Turn dial to the right (CW) until the dial completely stops (one revolution or less).
5. Turn safe handle to unlock and open door.

Dial Lock - Operating Instructions

- 4x) Turn Left 4 times
- 3x) Turn Right 3 times
- 2x) Turn Left 2 times
- 1x) Turn Right 1 time or less to unlock

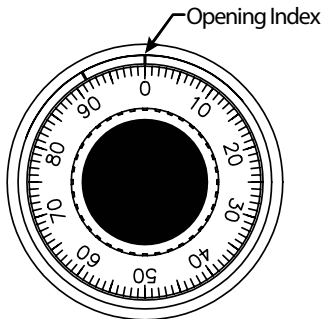

Figure 1.

Dial Lock - Setting A New Combination

**To change the combination, you will need to know the existing combination and have a La Gard change key (p/n 1307).*

Caution: When selecting a combination, choose a three number sequence from 0 - 99. Never select numbers 89 to 20 as the last number of the combination. This is the "Forbidden Zone" and can cause the lock to malfunction.

For security purposes, do not select a combination easily attained from personal data such as birth date, phone number, etc.

1. Dial the existing combination using the line at the 11 O'clock position when dialing your combination. This line is known as the changing index. (Figure 2.)
2. STOP the dial on the third number of the combination

Dial Lock - Setting A New Combination

3. Insert the change key into the change key hole. (Figure 3.)

Note: If the change key does not go in easily, the wheels are not aligned. Repeat steps 1 - 3.

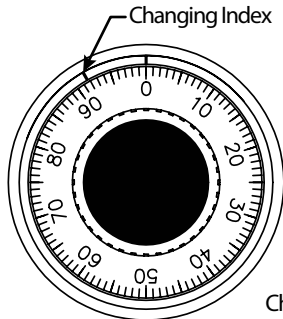

Figure 2.

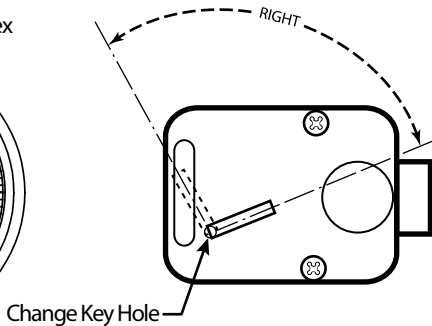

Figure 3.

Dial Lock - Setting A New Combination

4. Turn the change key to the right (CW) one-quarter turn until the key stops. Leave the change key in the lock while setting the new combination.
5. Next turn the dial to the left (CCW) at least four complete rotations to clear the lock. The lock is now ready to accept the new combination.

Caution: Do not spin the dial to clear the lock.

6. Set the new combination using the changing index at the 11 O'clock position:



Turn the dial left (CCW) passing the first number in the combination three times. Then stop exactly on the number the fourth time.

Dial Lock - Setting A New Combination



Turn the dial right (CW) passing the next number in the combination two times. Then stop exactly on the number the third time.



Turn the dial left (CCW) passing the last number in the combination one time. Then stop exactly on the number the second time.

7. Hold the Dial to prevent movement and turn the change key to the left (CCW) one quarter turn.
8. Remove the change key. The new combination is now set.
9. Test the new combination several times with the door open before locking the safe.

Electronic Lock Identification

Your safe will be equipped with one of two possible electronic lock types depending on when your safe was purchased or choice of lock finish. Both are high-security commercial grade locks with comparable features, but the instructions for use differ.

Electronic Lock - Black rubber dome keys with white lettering

Gen II Electronic Lock - Gray numeral keys with a green enter key

Simply use this graphic to visually identify which lock your safe is equipped with. Electronic Lock instructions are on the following page and Gen II Electronic Lock instructions begin on [page 27](#)

Electronic Lock Identification



Electronic Lock



Gen II Electronic Lock

Electronic Lock

The electronic lock is our most popular lock due to its simplicity and ease of use. This industrial grade keypad lock offers convenience second to none and has proven it's worth over many years of both commercial and residential service.

Electronic Lock Features:

- U. L. listed - Group 2 high security lock*
- Wrong try penalty initiates lockout mode for 5 minutes after 3 incorrect entry codes.*
- External battery compartment is conveniently accessible under keypad and utilizes standard 9-volt batteries. Duracell alkaline batteries are recommended.*
- Made in the U.S.A.*

Electronic Lock - Operating Tips

Please keep these tips in mind when utilizing your electronic lock:

- 1. After 3 incorrect entry codes the lock will timeout for 5 minutes.*
- 2. Avoid putting pressure on the handle during combination entry as this may cause a locking bolt malfunction.*
- 3. Once the correct combination is entered you'll have 3 seconds to turn the safe's handle.*
- 4. Prior to opening the safe make sure the handle is turned completely to the locked position.
Right side hinges = handle should be fully counter-clockwise.
Left side hinges = handle should be fully clockwise.*
- 5. In the open position the safe's handle will rotate approximately 20 degrees.*

Electronic Lock - Operating Instructions

1. Enter 6 digit combination using lock keypad.
The lock will signal a valid combination entry with a double signal.
2. Turn safe handle to unlock and open door.

Note:

- *Repeated beeping during an opening indicates that the battery is low and should be replaced.*
- *Invalid combination entry: Lock signals three times.*
- *Wrong try penalty entry of three consecutive invalid combinations will initiate a 5 minute lock out period, during which time the LED flashes red at 10 second interval.*

Electronic Lock - Setting a New Combination

**Always change combination with door open*

1. Enter six zeros.
2. Enter existing 6 digit combination.
3. Enter new 6 digit combination two times consecutively.
4. **Before closing door** Test new combination to verify proper operation.

Note: Locking bolts need to be retracted prior to shutting door.

Electronic Lock - Changing Batteries

1. Remove keypad by gently lifting straight up and tilting back.
**Caution keypad cable only has a few inches of free length.*
2. Remove both of the old batteries.
3. Connect one 9-Volt Alkaline battery (Duracell only) to each battery clip.
4. Insert batteries into bottom of housing.
5. Replace by placing the keypad on its mounting pins and sliding down until keypad is firmly locked into position.

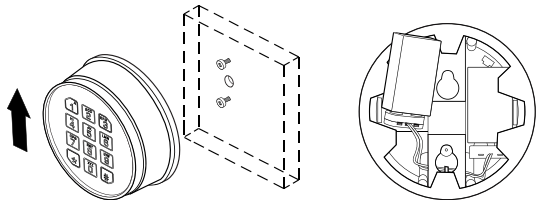

Electronic Lock - Sending Silent Distress Signal

**Only available if silent signal alarm lock feature was purchased.*

1. To trigger silent signal alarm, enter existing combination varying the last digit up by one number.

Example:

Standard Combination: 1-2-3-4-5-6

To Trigger the Alarm: 1-2-3-4-5-7

Note: This will open the safe as usual, but will send the silent duress signal to the authorities.

GEN II Electronic Lock

The electronic lock is our most popular lock due to its simplicity and ease of use. This industrial grade keypad lock offers convenience second to none and has proven it's worth over many years of both commercial and residential service.

Electronic Lock Features:

- U. L. listed - Group 2 high security lock*
- Wrong try penalty initiates lockout mode for 5 minutes after 4 incorrect entry codes.*
- External battery compartment is conveniently accessible under keypad and utilizes standard 9-volt batteries. Duracell alkaline batteries are recommended.*
- Made in the U.S.A.*

GEN II Electronic Lock - Operating Tips

Please keep these tips in mind when utilizing your electronic lock:

- 1. After 4 incorrect entry codes the lock will timeout for 5 minutes.*
- 2. Avoid putting pressure on the handle during combination entry as this may cause a locking bolt malfunction.*
- 3. Once the correct combination is entered you'll have 3 seconds to turn the safe's handle.*
- 4. Prior to opening the safe make sure the handle is turned completely to the locked position.
Right side hinges = handle should be fully counter-clockwise.
Left side hinges = handle should be fully clockwise.*
- 5. In the open position the safe's handle will rotate approximately 20 degrees.*

1. Enter 0 1 (User ID) _ _ _ _ _ (6 Digit Combo)

The lock will signal a valid combination entry with a double signal.





2. Lock will beep and flash green three times when the correct combination is entered.
3. Turn safe handle to unlock and open door.

Note:

- *Upon wake-up, the Keypad will emit 3 high beeps and 3 green LED flashes. **If the battery is low** this will be followed by 3 low LED beeps and 3 red LED flashes.*
- *Invalid combination entry: Lock signals three short beeps flashes red three times.*
- *Wrong Try Penalty: Entry of four consecutive invalid combinations will initiate a 5 minute lock out period, during which time the LED flashes red at 10 second interval.*

GEN II Electronic Lock - Setting a New Combination







**Always change the combination with the door open and test before closing the door and locking the safe.*

1. Press  #   0 1 (User ID) _ _ _ _ _ (Combo)
2. 0 1 (User ID) _ _ _ _ _ (New 6 Digit Combo)
3. 0 1 (User ID) _ _ _ _ _ (New 6 Digit Combo) 
4. **Before closing door** Test new combination to verify proper operation.

Note: Locking bolts need to be retracted prior to shutting door.







GEN II Electronic Lock - Adding a New User

**New User ID can be any number from 02-28*







1. Press     0 1 (User ID) _ _ _ _ _ (Combo)
2. _ _ (NEW ID *EX. 02*) _ _ _ _ _ (New 6 Digit Combo)
3.   

GEN II Electronic Lock - Turning Backlight Off/On

Turn **OFF** Backlight:

1. Press     0 1 (User ID) _ _ _ _ _ (Combo)
2.  

Turn **ON** Backlight:





1. Press     0 1 (User ID) _ _ _ _ _ (Combo)
2.  

GEN II Electronic Lock - Turning Sound Off/On

Turn **OFF** Sound:

1. Press  #  1 0 1 (User ID) _ _ _ _ _ (Combo)
2.  

Turn **ON** Sound:

1. Press  #  1 0 1 (User ID) _ _ _ _ _ (Combo)
2.  

GEN II Electronic Lock - Changing Batteries

1. Open the battery tray by depressing the release clip at the bottom of the lock.
2. Remove tray by pulling down to the right.
3. Replace the two 9-Volt batteries (use Duracell only).
4. Insert battery tray back into the keypad until you hear it "click" into place.

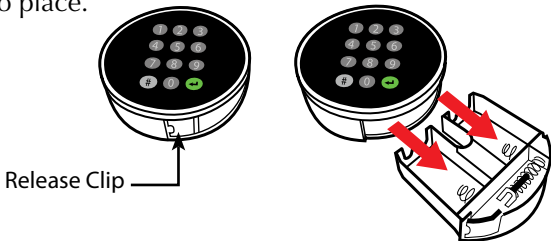

GEN II Electronic Lock - Sending Silent Distress Signal

**Only available if silent signal alarm lock feature was purchased.*

1. To trigger silent signal alarm, enter existing combination varying the last digit up by one number.

Example:

Standard Combination: 1-2-3-4-5-6

To Trigger the Alarm: 1-2-3-4-5-7

Note: This will open the safe as usual, but will send the silent duress signal to the authorities.

Biometric Lock - Operating Tips

The Biometric Lock offers the ultimate in security and convenience. Without a combination to remember or to be compromised, all that's necessary to securely gain access to the safe is your fingerprint. Please keep these tips in mind when utilizing your biometric lock:

1. Press any button to turn on the lock.
2. The Master Code must contain 8 digits or letters.
3. The Master Code is only used for programming.
It does NOT unlock the safe.
4. All User Codes must contain 6 digits or letters.
5. Keep the safe door in the open position when changing the lock code or fingerprint, and check lock function several times before closing the safe door.

Biometric Lock - Operating Tips

6. Periodically clean the fingerprint sensor with a dry cloth to ensure accurate readings.
7. Avoid putting pressure on the handle during combination entry as this may cause a locking bolt malfunction.
8. Once the correct combination is entered you'll have approx. four (4) seconds once code is accepted (lock displays: LOCK OPEN) to turn the safe's handle.
9. Prior to opening the safe make sure the handle is turned completely to the locked position.
Right side hinges = handle should be fully counter-clockwise.
Left side hinges = handle should be fully clockwise.
10. In the open position, the safe's handle will rotate approximately 20 degrees.

Unlocking with User Code

1. Press any button, lock will display **ENTER CODE**.
2. Enter 6 digit code, it will signal twice and display **LOCK OPEN**
3. Turn handle and open door.

Note: Do not apply pressure to handle prior to lock display stating LOCK OPEN.

Note: The lock will remain unlocked for 4 seconds to allow time to open the safe, after which it will automatically re-lock once the handle is turned back to the locked position.

Unlocking with Fingerprint

**This function can only be used once a finger is enrolled and the entry method is set to a fingerprint reading mode.*

1. Press **P** (or button on front of lock housing), the lock will beep twice, then press **P** again.
2. Place finger on sensor (lock will signal with one short beep, followed by two long beeps).
3. Turn handle and open door.

Note: Do not apply pressure to handle prior to lock display stating LOCK OPEN.

Note: The lock will remain unlocked for 4 seconds to allow time to open the safe, after which it will automatically re-lock once the handle is turned back to the locked position.

Biometric Lock - Setting Master Code

1. Press any button to turn on lock.
2. Press and hold **0** digit until displays reads **MASTER CODE**.
3. Enter **0** digit eight (8) times.
4. Enter your existing eight (8) digit Master Code one time.
5. Enter your NEW eight (8) digit Master Code two times.
If a valid code is entered the display will show
MASTER CODE UPDATED.

Note: Test lock operation several times before closing the door. In case of a mistake, display will show CONFIRM CODE, NOT MATCH and the old code will still be valid. Wait thirty seconds and repeat steps above.

Biometric Lock - Setting User Code

1. Press any button to turn on lock.
2. Enter **0** digit six (6) times when displays reads **ENTER CODE**.
3. Enter your existing six (6) digit User Code one time.
4. Enter your NEW six (6) digit User Code two times.
If a valid code is entered the display will show
CODE CHANGED!

Note: Test lock operation several times before closing the door. In case of a mistake, display will show CONFIRM CODE, NOT MATCH and the old code will still be valid. Wait thirty seconds and repeat steps above.

Biometric Lock - Enrolling Fingerprint for the First Time

1. Press any button to turn on lock.
2. Press and hold **0** digit until displays reads **Master Code**.
3. Enter 8 digit master code.
4. Press **P** six (6) times to select the User Menu, the display will show **USERS ON/OFF?**
5. Press OK to view the User status, the display will show **USERS ON/OFF, (XX - XX)**.
6. Enter User ID **02**, display will show **USER ID = 2, DISABLE?**
7. Press **P** four (4) times, display will show **USER ID = X, RE-ENROLL?**
8. Press **OK**, display will show **FINGERPRINT NUMBER = 1**.

Biometric Lock - Enrolling Fingerprint for the First Time

9. Press **OK**, the display will show, **SCAN YOUR FINGER** then **2nd SCANNING** and then **3rd SCANNING**.

- *Finger should be lifted after each scan, then quickly replaced so that three separate scans are made.*

10. Once scanning is completed, the display will show **ANOTHER FINGER**.

- *The system offers the option of scanning up to three (3) fingers for each User or the Manager.*
- *Repeat this procedure for each fingerprint to be enrolled for this User.*

11. Press **OK** to confirm and enroll another fingerprint or **P** to exit, display will show **FINGERPRINT, SUCCESS**.

Congratulations you have successfully enrolled a fingerprint!

Biometric Lock - Adding a New User

1. Press any button to turn on lock.
2. Press and hold **0** digit until displays reads **MASTER CODE.**
3. Enter 8 digit master code.
4. Press **P** six (6) times to select the User Menu, the display will show **USERS ON/OFF?**
5. Press **OK** to view the User status, the display will show **USERS ON/OFF, (XX - XX).**
6. Enter User ID (XX) of 03 or greater, display will show **USER ID = X, INSTALL?**
7. Press **OK** to install User, the display will show **NEW CODE, X-X-X-X-X-X.**

Biometric Lock - Adding a New User

8. Enter a new six (6) digit code, display will show **CONFIRM NEW, X-X-X-X-X-X.**
9. Enter new six (6) digit code a second time to confirm, display will show **ACCESS LOCK, -----.**

Note: If the lock is set to Code Only, steps 10 and 11 will not appear. Fingerprint mode needs to be enabled before you can enroll a fingerprint. Please refer to the directions for Changing Operating Modes to enable fingerprint scanning.

10. Enter **1** and press **OK**, display will show **FINGERPRINT NUMBER = 1 then SCAN YOUR FINGER.**

Continue to the next page for additional instructions.

11. Place finger on the reader. It will beep once and begin scan, then the lock will beep again and the display will show, **2nd SCANNING**, followed by the final beep and **3rd SCANNING**.

Note: Finger should be lifted after each scan, then quickly replaced so that three separate scans are made.

12. Once scanning is completed, the display will show **ANOTHER FINGER?**

- *The system offers the option of scanning up to three (3) fingers for each User or the Manager.*
- *Repeat this procedure for each fingerprint to be enrolled for this User.*
- *Note: If safe/vault is equipped with Silent Signal Alarm the 3rd finger enrolled will be used as the "duress finger".*

Biometric Lock - Adding a New User

- 13a. *Standard Locks (not equipped with silent signal alarm):*
Press **OK** to confirm and enroll another fingerprint or **P** to bypass, display will show **USER IS, MANAGER?**
- 13b. *Locks Equipped with Silent Signal Alarm:*
Press **OK** to confirm and enroll 2nd fingerprint.
Press **OK** to confirm and enroll 3rd fingerprint.
Once the 3rd finger is enrolled display reads:
FINGER 3 IS DURESS?
14. Press **OK** to accept or **P** to bypass, display will show,
TIME DELAY, OVERRIDE?
15. Press **OK** to accept or **P** to bypass, display will show,
USER = X, INSTALLED!

Congratulations you have successfully added a new User!

Biometric Lock - Deleting A User

1. Press any button to turn on lock.
2. Press and hold **0** digit until displays reads **MASTER CODE**.
3. Enter 8 digit master code.
4. Press **P** six (6) times to **USERS ON/OFF?**
5. Press OK to view the User status, the display will show **USERS ON/OFF, (XX - XX)**.
6. Enter User ID (XX) to select a user, display will show **USER ID = X, DISABLE?**
7. Press **P**, display will show **USER ID = X, DELETE?**
8. Press **OK**, display will show **USERS ON/OFF, (XX - XX)**.

Congratulations you've successfully deleted a user.

Biometric Lock - Changing Entry Method

1. Press any button to turn on lock.
2. Press and hold **0** digit until displays reads **MASTER CODE.**
3. Enter 8 digit master code.
4. Press **P** five (5) times to **SYSTEM SETUP.**
5. Press **OK** to select this function, display will show **LOCK INSTALL.**
6. Press **P** three (3) times, display will show **SYSTEM OPER. MODE.**
7. Press **OK** to enter the Menu, display will show **USER CODE.**

8. Press **P** to scroll through operation options.

Standard operating modes:

- USER CODE (default): 6 digit code is used to open lock.
- FINGER ONLY: A fingerprint is used to open lock.

Optional operating modes:

- 2 USER CODE: Two user codes must be used to open lock.
- FINGER + CODE: Both a fingerprint and user code must be used to open lock.
- 2FINGERS: Two fingerprints must be used to open lock.
- 2FINGERS + CODE: Two fingerprints and a user code must be used to open lock.

Biometric Lock - Changing Entry Method

9. After scrolling to appropriate operation, press OK to select, display will show **SYSTEM OPER. MODE.**
10. Press **P** three (3) times to esc from menu.
11. Press **OK** to select, display will show **SYSTEM SETUP.**
12. Press **P** four (4) times, display will show **DO YOU WANT TO QUIT?**
13. Press **OK.**

Your desired entry method is now set.

*Note: When entry method is set to finger only the lock will display **P TO SCAN OK FOR CODE** upon start up.*

Biometric Lock - Emergency Opening with Code Only

These instructions allow the owner to grant access to the safe in the event the owner isn't present or their fingerprint isn't available.

1. Press any button to turn on lock.
2. Press and hold 0 digit until displays reads **MASTER CODE.**
3. Enter 8 digit master code.
4. Press **P** five (5) times to **SYSTEM SETUP.**
5. Press **OK** to select this function, display will show **LOCK INSTALL.**
6. Press **P** three (3) times, display will show **SYSTEM OPER. MODE.**

Biometric Lock - Emergency Opening with Code Only

7. Press **OK** to enter the Menu.
8. Press **P** to scroll through operation options until display shows **USER CODE.**
9. Press **OK** to select, display will show **SYSTEM OPER. MODE.**
10. Press **P** three (3) times to esc from menu.
11. Press **OK** to select, display will show **SYSTEM SETUP.**
12. Press **P** four (4) times, display will show **Do You Want to QUIT?.**

Continue to the next page for further instructions.

Biometric Lock - Emergency Opening with Code Only

13. Press **OK** . The lock can now be opened with the six digit safe combination.
14. Wait for the lock to power off and the display goes blank.
15. Press any button, lock will display **Enter Code**.
16. Enter 6 digit safe combination, lock will signal twice and display **LOCK OPEN**.
17. Turn handle and open door.

Note: Do not apply pressure to handle prior to lock display stating "Lock Open".

How to recognize when the lock batteries need replacing:

- Lock will display **WARNING! BATTERY LOW**

Note: If lock continues to show WARNING! BATTERY LOW after batteries are replaced. Enter combo and unlock safe to reset.

- If you notice a distinct change in the pitch of the beeps.
- Erratic or inconsistent lock operation.
- If the lock beeps 15 times rapidly when you try to open it, but remains locked, then it is time to change the batteries.

Continue to the next page for instructions.

Biometric Lock - Changing The Batteries

1. Open the front access door of the entry display to reveal the lock keypad and battery compartment covers.
2. Unscrew the allen bolts on both sides of the lock keypad which secure the faceplates of the two battery compartments.

Note: 1/16" hex driver included with safe.

3. Remove the faceplates of both battery compartments.
4. Unsnap the wired leads and replace the two 9-volt alkaline batteries.
5. Insert batteries back into compartment and Re-attach faceplate cover with the two allen bolts.

Biometric Lock - Changing The Batteries

Note: If lock continues to show WARNING! BATTERY LOW after batteries are replaced. Enter combo and unlock safe to reset the lock.

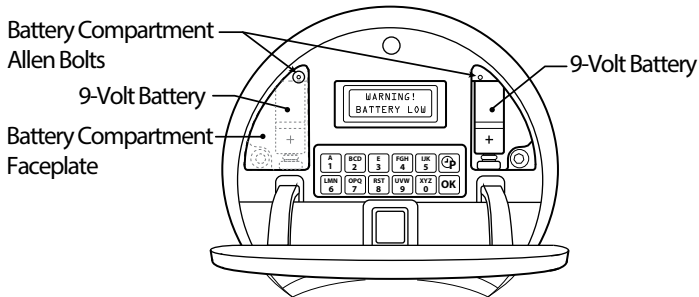

CHRONOS Biometric Lock - Changing The Batteries

- The Chronos Biometric lock has an additional keypad for entry that is powered using batteries. This unit allows the safe to be opened in the event of power loss or a rare failure of the main entry system.
- The main entry system is powered from the AC cable exiting the safe at the rear.
- The secondary keypad's batteries will need to be replaced every 1-3 years.

CHRONOS Biometric Lock - Changing The Batteries

The second keypad is located behind the access door on both the Oval And Integrated Chronos displays and both are accessed by removing the cover plate.

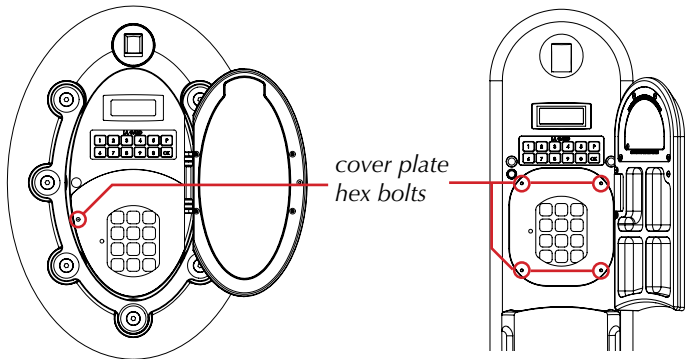

Chronos Oval Display

The secondary keypad is located under the main horizontal keypad.

To access the keypad remove the hex bolt located on the opposite side of the cover plate to the hinge.

Carefully lift and slide the plate from under the hinge and set aside with the hex bolt.

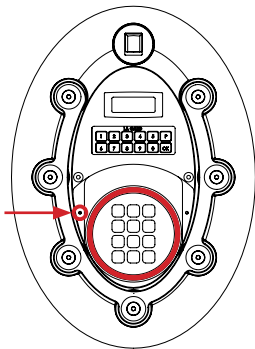

CHRONOS Biometric Lock - Changing The Batteries

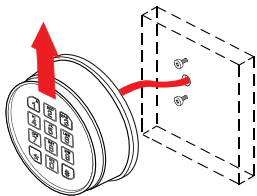

Remove keypad by gently lifting straight up and tilting back.

**Caution keypad cable only has a few inches of free length.*

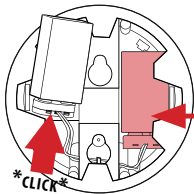

Connect one 9-Volt Alkaline battery (Duracell only) to each battery clip.

Insert batteries into both sides of the housing.

CHRONOS Biometric Lock - Changing The Batteries

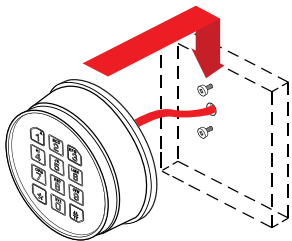

Replace by placing the keypad on its mounting pins and sliding down until keypad is firmly locked into position.

**Note: Test the keypad using the supplied code. If the keypad gives a low battery indication remove and reseal the battery clips.*

Finally replace the cover plate by sliding it under the hinge side then screw in the hex bolt.

Chronos Integrated Display

The secondary keypad is located under the main horizontal keypad.

To access the keypad remove the 4 hex bolts located on each corner of the cover plate.

Remove the plate and set aside with the 4 hex bolts.

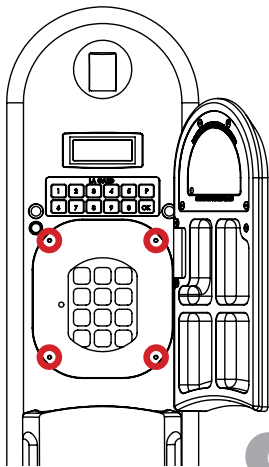

CHRONOS Biometric Lock - Changing The Batteries

Remove keypad by lifting straight up and tilting back and sliding the unit gently from the cavity.

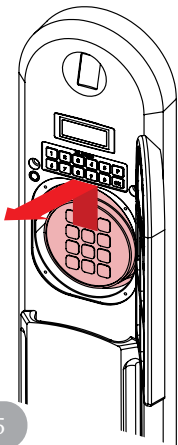

**Caution keypad cable only has a few inches of free length.*

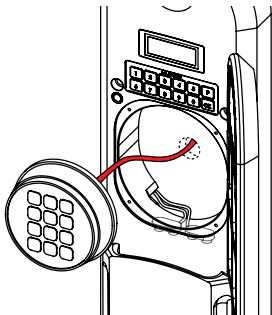

CHRONOS Biometric Lock - Changing The Batteries

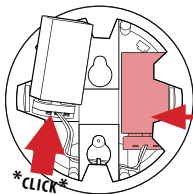

Connect one 9-Volt Alkaline battery (Duracell only) to each battery clip.

Insert batteries into both sides of the housing.

Replace by placing the keypad on its mounting pins and sliding down until keypad is firmly locked into position.

**Note: Test the keypad using the supplied code. If the keypad gives a low battery indication remove and reseal the battery clips.*

Replace the cover plate by screwing in the 4 hex bolts.

CHRONOS Biometric Lock - Loss of AC power

The primary biometric entry panel , for both Oval and Integrated designs, is powered from the AC cable exiting the rear of your safe. In the event of AC power loss or extended disconnection from the AC power (for transit or relocation) the main entry can be powered using 9v block batteries.

Note: Batteries should NOT be attached whilst the safe is powered from the wall AC outlet. Always disconnect the AC power before connecting batteries.

All Chronos safes have a redundant keypad that can be used instead of the main entry method for quick entry into the safe in the event of AC power loss.

Chronos Oval Display

Remove the cover plate and secondary keypad.

Note: Instructions are on page 49 and 50

Locate the two sets of wires, each with a 9v connector attached, under the horizontal keypad.

Attach a 9v block battery to each connector and slot the batteries into the two cavities on either side of the secondary keypad area.

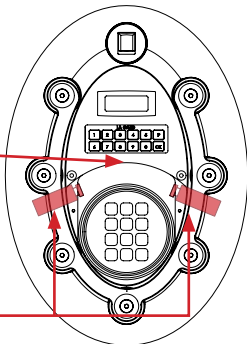

CHRONOS Biometric Lock - Loss of AC power

Before replacing the cover plate test the primary entry by using your 6 digit code or using the biometric fingerprint scanner.

If the keypad behaves erratically or returns a 15 beep “low battery” warning try removing the batteries and ensure the clips are connected fully and test again.

Now replace the cover plate using the hex bolt

Note: any 1/16th inch hex driver can be used.

Both the primary and secondary keypads will function to allow entry to the safe without AC power.

Chronos Integrated Display

Remove the cover plate and secondary keypad.

Note: Instructions are on page 52 and 53

With the keypad removed you will see a set of wires with two connectors at the bottom of the cavity.

Connect a 9v block battery to each connector and insert them into the space at the bottom of the cavity.

see page 57 for replacing the cover plate

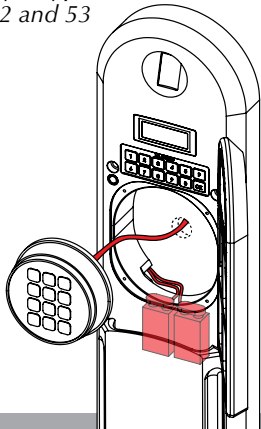

Vault Door Lock - Electronic Lock with Dial Lock Backup

Brown Safe vault doors utilize a highly secure double lock system for controlling access. With this system an electronic keypad lock is used as well as a mechanical dial lock to provide the user with the highest degree of security and reliability.

Electronic Lock Features:

- *U. L. listed - Group 2 high security lock.*
- *Wrong try penalty initiates lockout mode for 5 minutes after 3 incorrect entry codes.*
- *External battery compartment is conveniently accessible under keypad and utilizes standard 9-volt batteries.*

Mechanical Dial Lock Features:

- *3 combination wheels produces 1,000,000 possible combinations.*
- *Integral relock trigger sets off relockers if lock is tampered with.*
- *Brass wheels and lever offers long & dependable lock life.*
- *Dialing tolerance = +/- .5 degrees.*

Vault Door Lock - Operating Tips

Please keep these tips in mind when utilizing your electronic lock:

- 1. After 3 incorrect entry codes the lock will timeout for 5 minutes.*
- 2. Avoid putting pressure on the handle during combination entry as this may cause a locking bolt malfunction.*
- 3. Once the correct combination is entered you'll have 3 seconds to turn the safe's handle.*
- 4. Prior to opening the safe make sure the handle is turned completely to the locked position.
Right side hinges = handle should be fully counter-clockwise.
Left side hinges = handle should be fully clockwise.*
- 5. In the open position the safe's handle will rotate approximately 90 degrees.*

Vault Door Lock - Operating Instructions

1. Enter 6 digit combination using electronic lock keypad.
The lock will signal a valid combination entry with a double signal.
2. Turn combination dial one turn clockwise until dial stops.
Note: Dial normally stops between 10 and 90. Once code is entered you have 3 seconds to turn Dial to open position.
Tip - Turn dial to 50 prior to entering combination to facilitate a quick & easy turn to open position.
3. Turn safe handle to unlock and open door.
 - *Repeated beeping during an opening indicates that the battery is low and should be replaced.*
 - *Invalid combination entry: Lock signals three times.*
 - *Wrong try penalty entry of three consecutive invalid combinations will initiate a 5 minute lock out period, during which time the LED flashes red at 10 second interval.*
4. To lock the door: Close door and turn handle to the locked position then spin the dial one turn counterclockwise.

Vault Door Lock - Setting A New Combination

**Always change combination with door open*

Electronic Lock

1. Enter six zeros.
2. Enter existing 6 digit combination.
3. Enter new 6 digit combination two times consecutively.
4. **Before closing door** Test new combination to verify proper operation.

Note: Locking bolts need to be retracted prior to shutting door.

Vault Door Lock - Changing Batteries

1. Remove keypad by gently lifting straight up and tilting back.
**Caution keypad cable only has a few inches of free length.*
2. Remove both of the old batteries.
3. Connect one 9-Volt Alkaline battery (Duracell only) to each battery clip.
4. Insert batteries into bottom of housing.
5. Replace by placing the keypad on its mounting pins and sliding down until keypad is firmly locked into position.

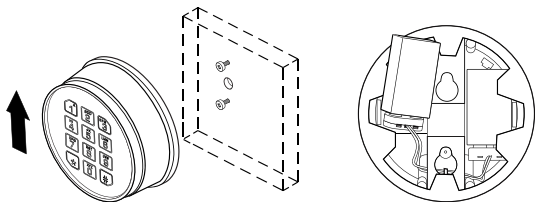

Vault Door Lock - Dial Lock Operating Instructions

**Always use the line at the 12 o'clock position when dialing your combination. This line is known as the opening index.*

1. Turn dial five times counter clockwise to your first combination number.
2. Turn dial clockwise passing second combination number twice and stopping on the number the third time.
3. Turn dial counter clockwise passing third combination number once and stopping on the number the second time.
4. Turn dial clockwise until the dial completely stops (one revolution or less).
5. Turn safe handle to open door.

Note: See pages 13-14 for a diagram.

Vault Door Lock - Inner Escape Device Operation

Brown Safe vault doors equipped with an inner escape device enable the user to open the vault door from inside the vault. Follow the instructions below to learn how to operate the inner escape device.

1. Unlock and open the cover of the inner escape device to access the opening mechanism.
2. Locate the red lever
3. Move the red lever towards the opening side of vault door until it stops.
4. Turn handle towards the opening side of vault door until it stops and open door.

Note: Handle rotates approximately 90 degrees.

Vault Door Lock - Inner Escape Device Operation

Red Lever

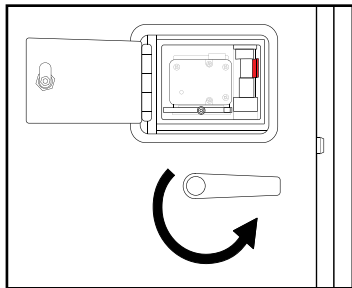
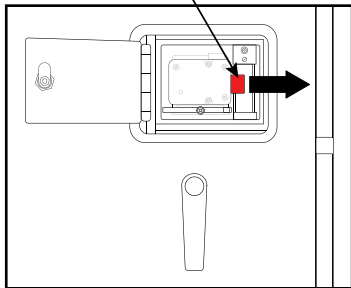

Vault Door Lock - Panic Slide Latch Operation

Brown Safe vault doors equipped with a panic slide latch allow the vault to be used as a panic room. Follow the instructions below to engage a lock out feature from the interior of the vault.

1. Close the vault door and turn the handle to engage the locking bolts.
2. Unlock and open the cover of the inner escape device to access the locking mechanism.
3. Locate the yellow lever on the panic slide latch.
4. Move the yellow lever towards the opening side of vault door until it stops.

Note: Take note that the yellow lever covers the locking mechanism so that it can no longer move.

Vault Door Lock - Panic Slide Latch Operation

5. The vault door will now remain locked until the yellow lever is moved back into the open position.

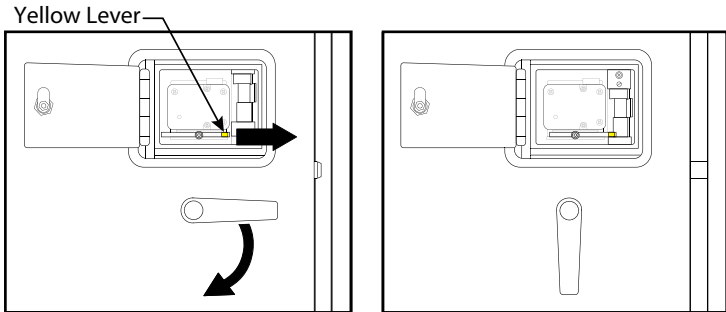

3 Movement Mechanical Timelock

1. Insert winding key through hole in timelock cover directly below time movement.

Note: Be sure key is fully inserted before winding.

2. Rotate key to set desired amount of time the safe lock is to remain inoperable.

Note: Each mark on the dial represents one hour.

3. Repeat steps 1-2 for each movement. Set the dials to the same amount of time for redundancy.

4. Depress set switch in center of timelock cover to engage. The timelock is now in the locked position.

Note: Once pressed and the door closed the safe cannot be opened until the set amount of time has elapsed.

3 Movement Mechanical Timelock

Timelock Release: As a safety feature the timelock can be changed to the unlocked position. A manual release pin is located on the right side of the cover next to the engage switch used to set the timelock. Slide the manual release pin to the right to disengage the timelock.

Note: This only disengages the timelock operation. The movements will not zero and will need to wind down the set amount of time if a mistake in programming was made.

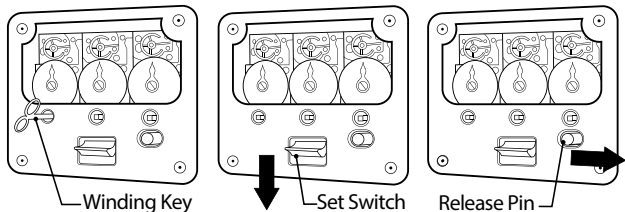

Silent Signal Alert

Triggered by either a hidden button or an alternate unlock entry code, safes equipped with the silent signal alert feature interface directly with the alarm or home automation system to send an undetectable alert to notify security authorities in the event that the safe owner is forced to open the safe against their will.

Sending a Distress Signal via Electronic Lock:

**Only available if silent signal alarm lock feature was purchased.*

To trigger silent signal alarm function, enter existing combination varying the last digit up by one number.

Example:

Standard Combination: 1-2-3-4-5-6

To Trigger the Alarm: 1-2-3-4-5-7

Note: See page 4 for initial silent signal setup guide.

Sending a Duress Signal via Hidden Panic Button:

1. Unlock safe and open door normally.
2. Locate hidden panic button on interior of door near the locking bolts.
3. Press the hidden panic button to send an alert to your home monitoring system to immediately notify security authorities.

Watch Winder Operation - Programmable Winders

Orbita Programmable winders allow the user to designate winding cycles of 650, 800, 950, 1300 or 1600 Turns Per Day, with a choice of clockwise, counter-clockwise or automatic reversing rotation.

Mounting Watches:

1. Remove watch cushion from winder cup. Use one hand to hold the watch winder cup in place, then with the other hand pull the soft cushion from the cup. *Take care not to unseat the winder cup from its mounting post.*
2. Securely mount watch to cushion and insert back into winder cup.
3. If the winder cup was unseated from the mounting post, then replace winder cup back inside winder housing by pushing straight in as you rotate the cup until it seats fully in winder housing.

Note: Alternative size watch cushions are available if needed.

Watch Winder Operation - Programmable Winders

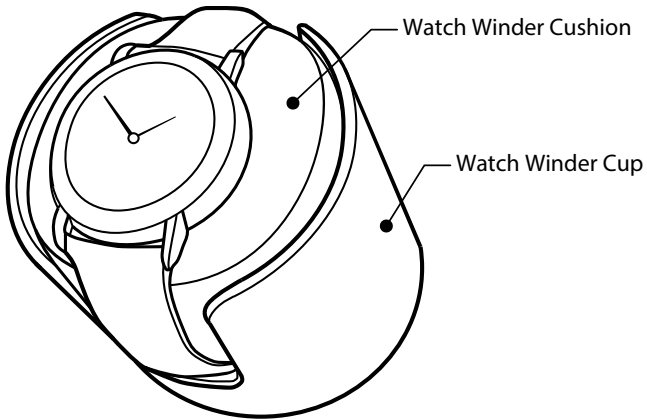

Turning On/Off Power to Watch Winders:

** Each winder has its own independent power switch so that they can be individually controlled.*

1. Remove winder cup by pulling straight out from face of watch panel.
2. Locate toggle switch inside winder housing.
3. Turning ON winder: Toggle toward the On (line) position to supply power to the winder.

Turning OFF winder: Toggle toward the Off (circle) position to disconnect power to that winder.

4. Replace winder cup so that it snaps firmly into place.

Watch Winder Operation - Programmable Winders

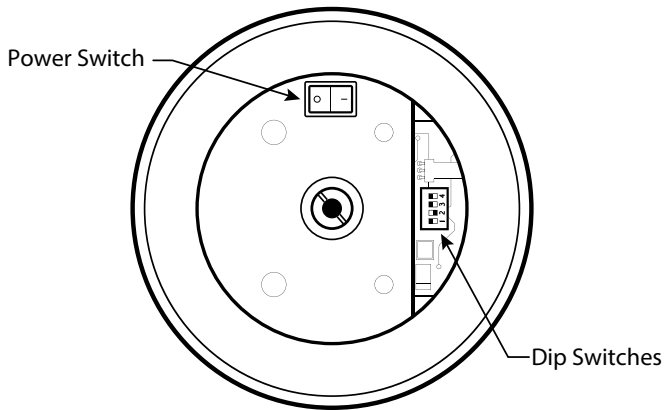

Setting Programmable Watch Winders:

** The rotation direction and duration of movement for each watch winder is controlled by dip switches located within each winder housing.*







1. Remove winder cup by pulling straight out from face of watch panel.
2. Locate dip switches inside winder housing.
3. Set dip switches using the program settings appropriate for your watch model.

Note: Winders come from the factory with a default setting of 800 Clockwise rotations per day.

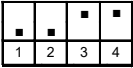
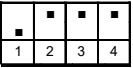
*Visit Orbita's online watch database to find the correct settings for specific watches at: **orbita.com/database-search/***

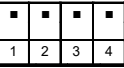
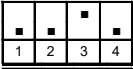
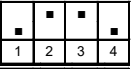
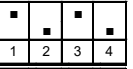
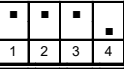
Watch Winder Operation - Programmable Winders

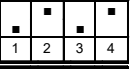
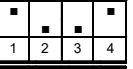
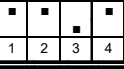
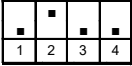
Programmable Watch Winder Settings:

Operating Mode	650 Turns Per Day	800 Turns Per Day	950 Turns Per Day	1600 Turns Per Day
Clockwise Rotation Only				
Counterclockwise Rotation Only				
Automatic Reversing				
	1300 Turns Per Day	1300 Turns Per Day		
Clockwise Rotation Only			Counterclockwise Rotation Only	

Watch Winder Operation - Rotorwind Modules

Orbita Rotorwind winders swing the watch, rather than rotating it, mimicking the natural action of the wrist.

Mounting Watches:

1. Remove watch cushion from winder cup. Use one hand to hold the watch winder cup in place, then with the other hand pull the soft cushion from the cup. *Take care not to unseat the winder cup from its mounting post.*
2. Securely mount watch to cushion and insert back into winder cup.
3. If the winder cup was unseated from the mounting post, then replace winder cup back inside winder housing by pushing straight in as you rotate the cup until it seats fully in winder housing.

Watch Winder Operation - Rotorwind Modules

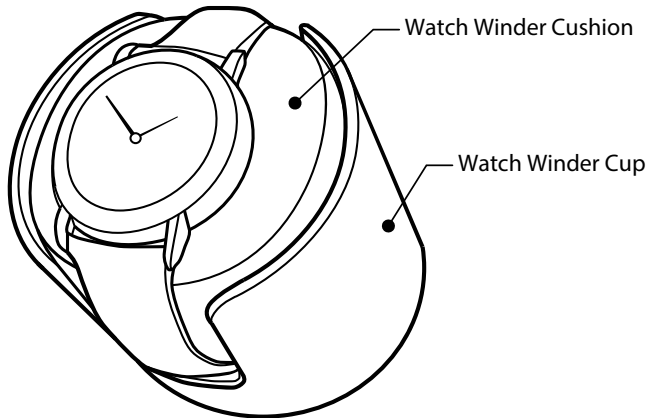

Turning On/Off Power to Watch Winders:

** Each winder has its own independent power switch so that they can be individually controlled.*

1. Remove winder cup by pulling straight out from face of watch panel.
2. Locate toggle switch inside winder housing.
3. Turning ON winder: Toggle toward the On (line) position to supply power to the winder.

Turning OFF winder: Toggle toward the Off (circle) position to disconnect power to that winder.

4. Replace winder cup so that it snaps firmly into place.

Watch Winder Operation - Rotorwind Modules

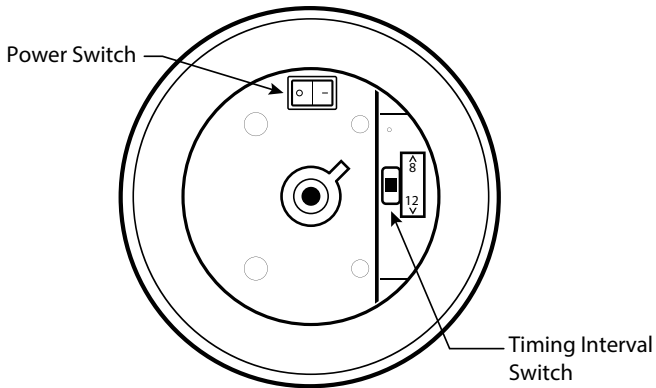

Watch Winder Operation - Rotorwind Modules

Unlike other watch winders which rotate a watch in order to wind it, the Rotorwind modules gently swing the watch instead. A semi-circular rotor, attached to the back of the mounting cup, is supported by two free-turning precision ball bearings which enables the “back and forth” motion when the cup is raised and then released from the 12 o’clock position at either 8 or 12 minute intervals.

8 Minute Interval (1200 - 1300 Turns per day):

This is the default setting and causes the watch to swing back and forth for several oscillations just as it would if it were being worn on the wrist.

12 Minute Interval (800 - 900 Turns per day):

This is the extended program and allows many watches that wind in both directions to remain fully wound while on the winder.

Setting The Timing Switch For 8 or 12 Minute Operation:

** Each winder has its own independent timing switch so that they can be individually controlled.*

1. Remove winder cup by pulling straight out from face of watch panel.
2. Locate the black slide switch near the red power button inside the winder housing.
3. Insert an object (screwdriver, pen, etc.) in the opening and slide the switch lever down to select 12 minute intervals or up to select 8 minute intervals.
4. Replace winder cup so that it snaps firmly into place.

Watch Winder Operation - Winder Carousel

The Winder Carousel groups watches circularly to maximize available space and button activated motors quickly rotate the stack in either direction for convenient access to timepieces.

1. Depress power switch to supply electricity to the carousel.

Note: This turns on power to the carousel only.

Winders are powered and controlled by their individual switches.

2. Depress carousel direction switch in the direction you would like the carousel to turn.

Warning: Do not change directions while the carousel is moving.

If so the power switch must be turned off and then back on after 4 seconds to reset the carousel.

3. Depress the carousel operation switch to turn the carousel.

Note: Each time the button is pressed the carousel will turn to the next set of winders and then stop. Press and hold the

operation switch to rotate the carousel continuously.

Watch Winder Operation - Winder Carousel

Winder Carousel Switches:

- Ⓐ Winder Power Switches
- Ⓑ Carousel Power Switch
- Ⓒ Direction Switch
- Ⓓ Operation Switch

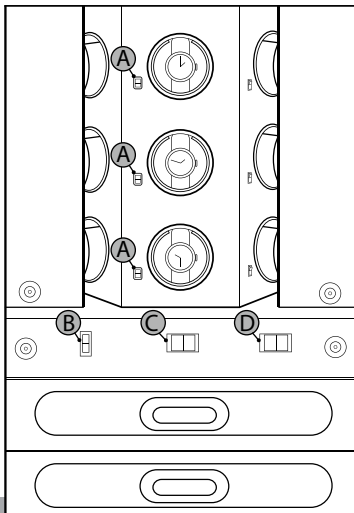

Safe Interior - Adjusting Shelves

To accommodate our client's specific needs and offer added flexibility, all interior shelves are adjustable.

1. Open safe and remove all contents resting on shelf.
2. Remove shelf from safe interior.
Note: Begin by lifting up on one side of shelf if tightly fitted.
3. Once shelf is removed and the shelf support brackets are visible, remove brackets by tilting up and pulling out.
4. Relocate the brackets to the desired location.
Note: Interior lining may need to be punctured to fit shelf bracket.
5. Replace shelf after all four supports brackets are securely in place.

Safe Interior - Adjusting Shelves

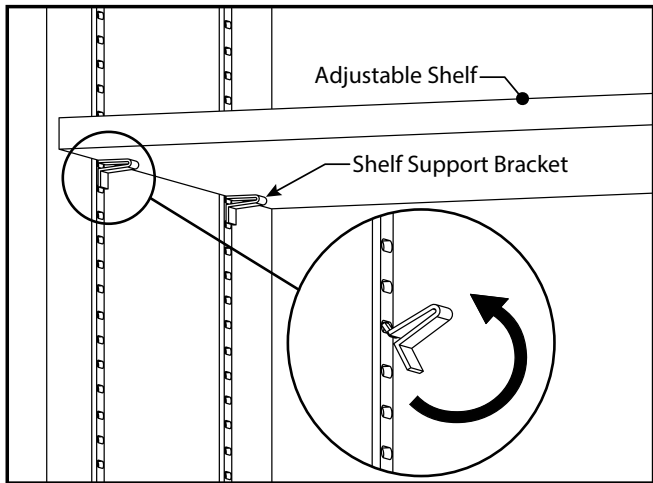

Safe Interior - Adjusting Shelves

To accommodate our client's specific needs and offer added flexibility, all interior shelves are adjustable.

1. Open safe and remove all contents resting on shelf.
2. Remove shelf from safe interior.
Note: Begin by lifting up on one side of shelf if tightly fitted.
3. Once shelf is removed and the shelf support brackets are visible, remove brackets by tilting up and pulling out.
4. Relocate the brackets to the desired location.
Note: Interior lining may need to be punctured to fit shelf bracket.
5. Replace shelf after all four supports brackets are securely in place.

Safe Interior - Adjusting Shelves

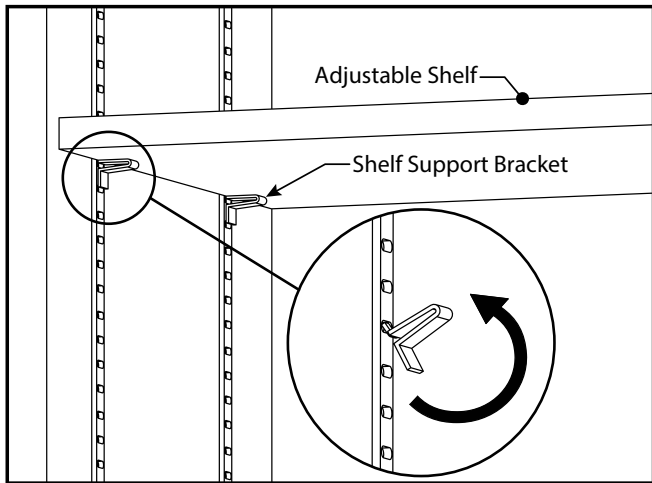

Safe Interior - Changing Jewelry Drawer Inserts

In an effort to supply you with the most convenient solution to organizing your valuables, Brown Safe has created a wide selection of drawer insert layout options and designed them to be interchangeable. Simply follow the instructions below to replace or relocate your drawer inserts.

1. Fully extend jewelry drawer.
2. Remove drawer insert by grasping the interior of the layout and lifting straight up from jewelry drawer.
3. Once the layout is removed relocate in an empty drawer by centering the layout over the drawer and firmly pressing downward.

Safe Interior - Changing Jewelry Drawer Inserts

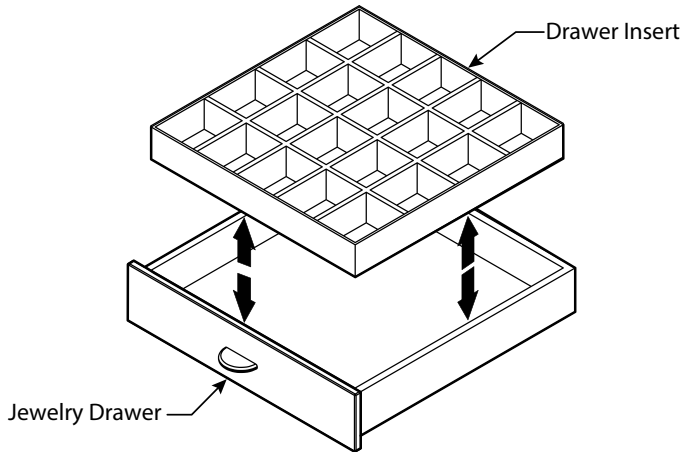

Safe Interior - Removing Drawer Detents

Drawer detents are installed on jewelry drawers to protect the drawers from damage during transit. These detents can be removed if desired, eliminating the initial stiffness felt when opening the jewelry drawers.

1. Fully extend jewelry drawer.
2. Remove jewelry drawer by pressing levers on sides of drawer in specified direction (one up, one down).
3. Once drawer is removed, drawer detents will be visible at the rear of the slide attached to the jewelry box unit. The detent is black plastic and shaped similar to the numeral 8.

Safe Interior - Removing Drawer Detents

4. Drawer detents can be removed using a slot screwdriver inserted into the space between the metal slide and the plastic detent. The detent should pop off.
5. Insert drawers back onto drawer slides and fully close (may be hard to close the first time).

Note: Drawer detents can be saved and used if the safe ever needs to be moved.

Safe Interior - Removing Standard Drawers

Brown Safe's Gem and Estate Series luxury safes make use of top quality drawer slides to accommodate reliable and convenient access to your valuables. These drawers can be removed by following the directions below.

1. Fully extend jewelry drawer.
2. Locate release levers on both drawer slides.
Note: There is one lever on the left side of the drawer and one lever on the right side of the drawer.
3. Remove jewelry drawer by lifting up on the left lever and pressing down on the right lever while simultaneously sliding the jewelry drawer out.

Safe Interior - Removing Standard Drawers

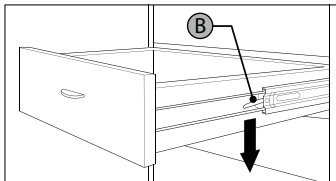
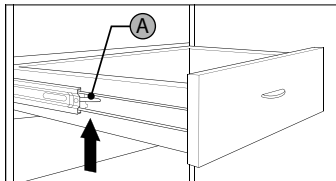

- Ⓐ Lift Up Left Lever
- Ⓑ Press Down Right Lever
- Ⓒ Pull Drawer Out

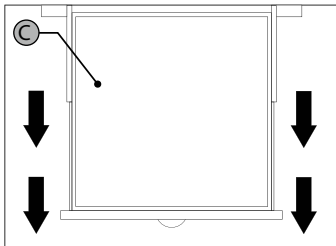

Safe Interior - Removing Undermount Drawers

Brown Safe's Chronos Series and Man Safes make use of refined undermount drawer slides to accommodate reliable and convenient access to your valuables. These drawers can be removed by following the simple directions below.

1. Fully extend jewelry drawer.
2. On the underside of the drawer, locate the two release levers on both drawer slides.
3. Remove jewelry drawer by depressing the release levers while simultaneously sliding the jewelry drawer out.

Safe Interior - Removing Undermount Drawers

Release Levers

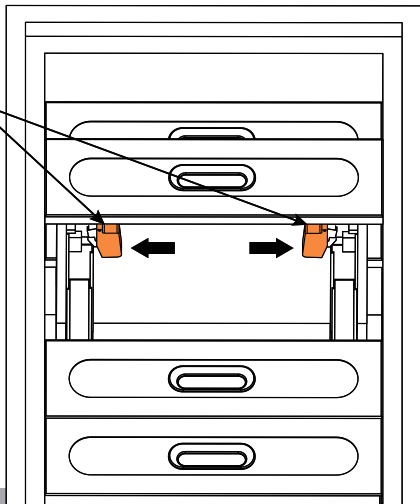

If you have any questions about using your new safe or need additional information please visit the Support Page at www.BrownSafe.com or contact us directly at:

Phone - (760) 233-2293

Email - Sales@BrownSafe.com

*Enjoy the security, convenience, and peace of mind
that comes with owning a Brown Safe!*

Brown Safe Manufacturing

1081 Poinsettia Ave.

Vista, CA 92081

United States

www.BrownSafe.com

Ph. (760) 233-2293

Fax: (760) 233-2297

Email: Sales@BrownSafe.com